



MAX

By **MTB**

MINIMUM SIZE
MAXIMUM EFFICIENCY

INPUT MATERIALS

N°1 copper cables



N°2 copper cables



Cat 5 copper cables



Aluminum cables / ACSR



Radiators



Automotive harnesses

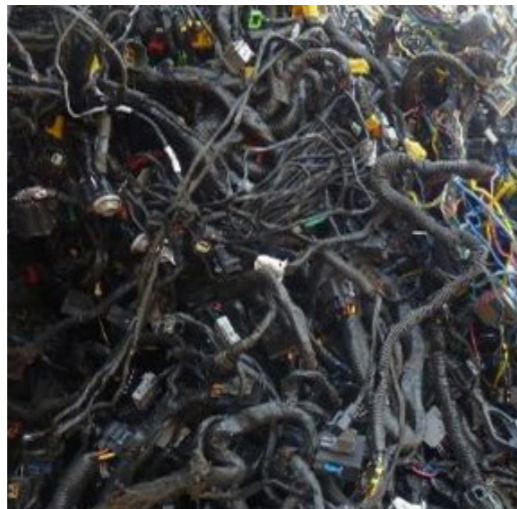

Shredder wires



OUTPUT PRODUCTS

Classified non-ferrous fractions



Big Copper



Fine Copper



Aluminum

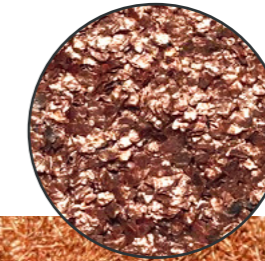

Copper flakes (OPTIONAL)

Other metallic fractions



Ferrous insert

Plastics



Mixed plastics



PE Plastic

CAPACITY UP TO 1T/H

OVER 40 YEARS OF EXPERIENCE IN FERROUS AND NON-FERROUS RECYCLING

MTB is considered as a pioneer in tomorrow's waste recycling. Concerned with the future of our planet, the company values « ZERO WASTE, PREMIUM QUALITY and FOR OUR CHILDREN » lead its development strategy. Both an operator and a manufacturer, MTB has highly-qualified experience in complex industrial waste recycling.

Why should you trust us? All MTB equipment is first tested and optimized on our recycling site before being launched for sale!

Be autonomous in recovering your own raw materials with this smart recycling process!

The MaX is a concentrate of innovation and MTB know-how. A minimal investment for high quality return.

No more compromising between size and quality. With MTB, you get the best without compromise. The MaX is the smallest chopping line ever, combining a robust build, proven separation, and the unmatched service and support MTB is renowned for.

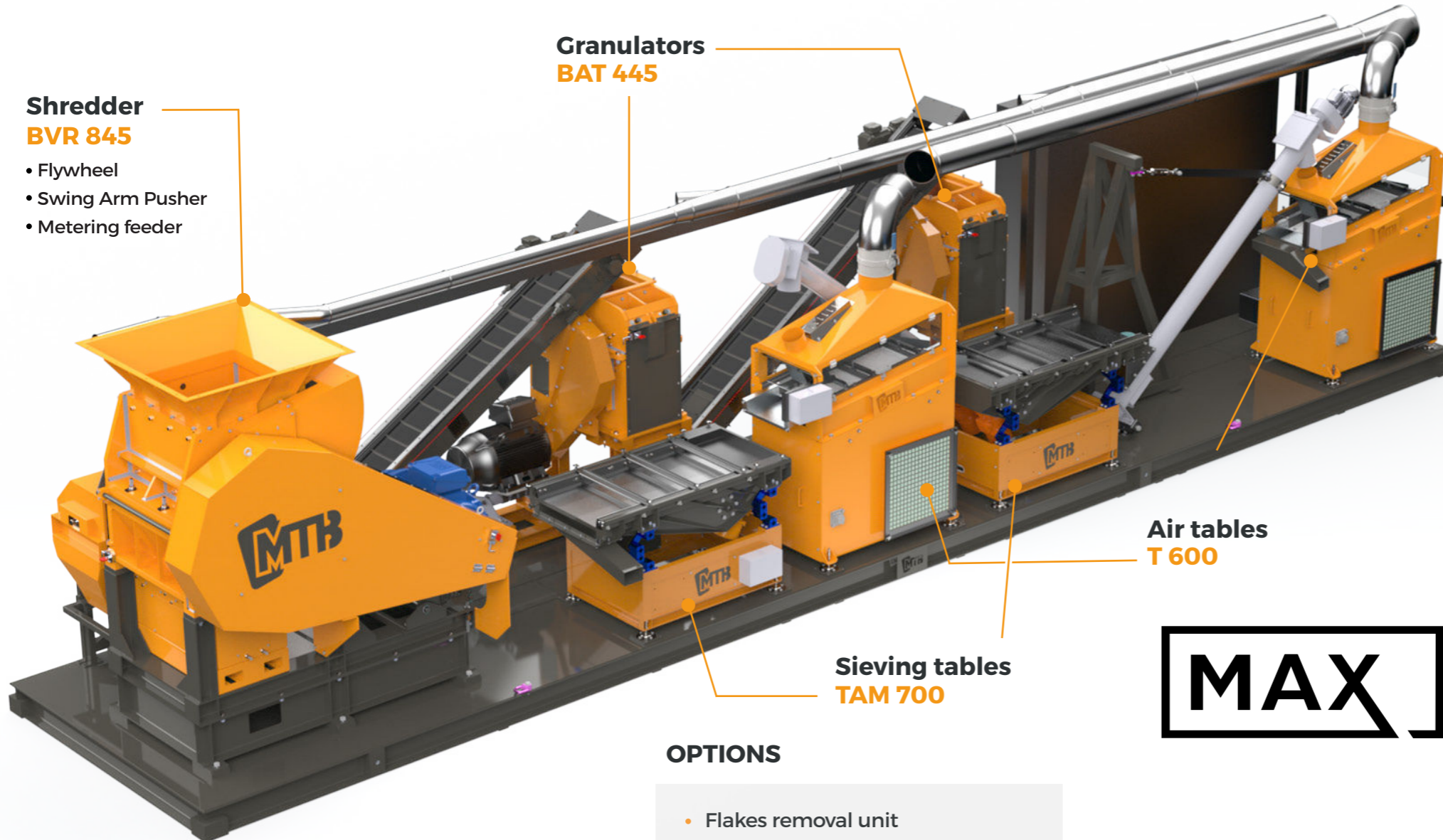
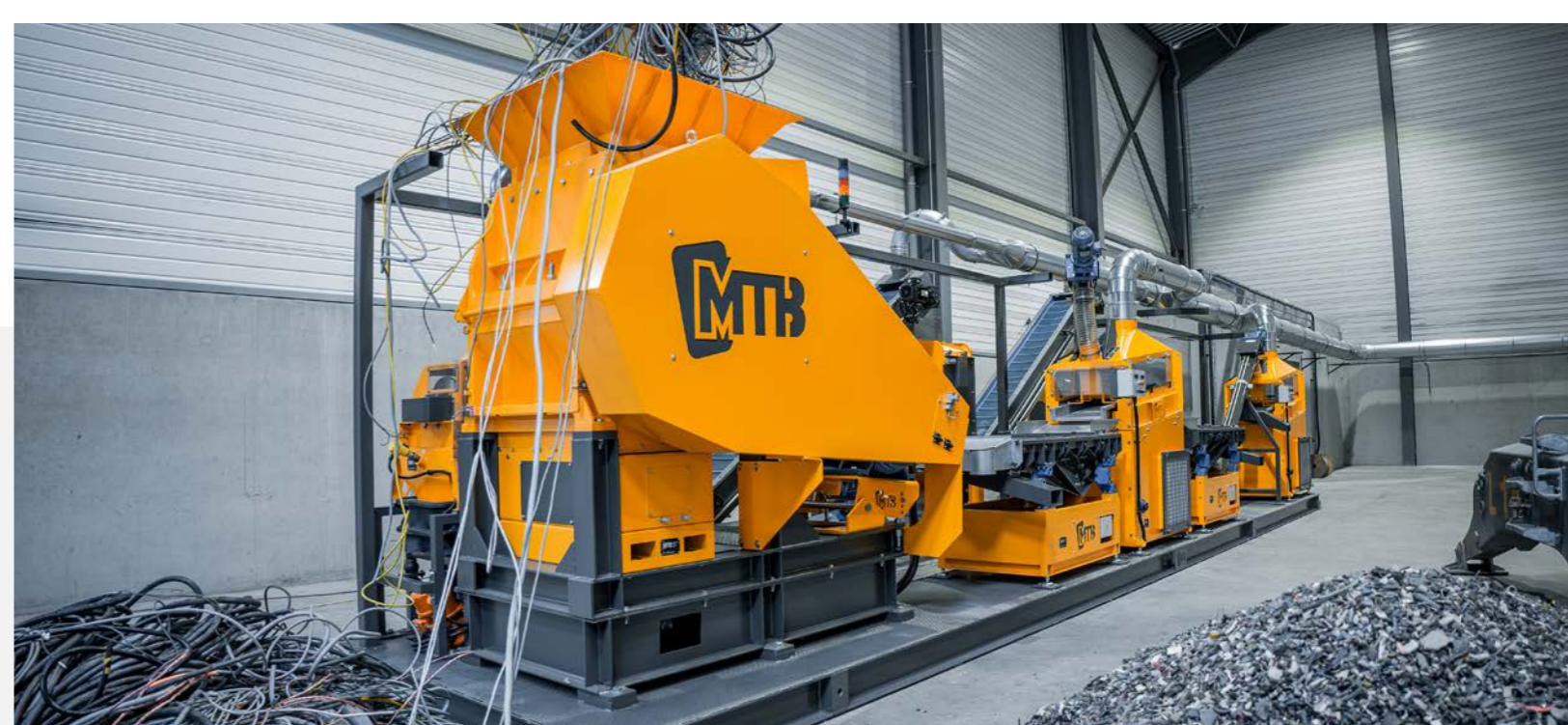

OPTIONS

- Flakes removal unit
- Extra plastic screening
- Turbo mill
- Set of discharge screw conveyors

MAX



SHREDDING AREA

Upgraded BVR 845 model

Pusher to boost throughput

Enlarged hopper for easier loading

Easy blade gapping

Flywheel
Higher torque to handle tougher pieces and avoid stalling

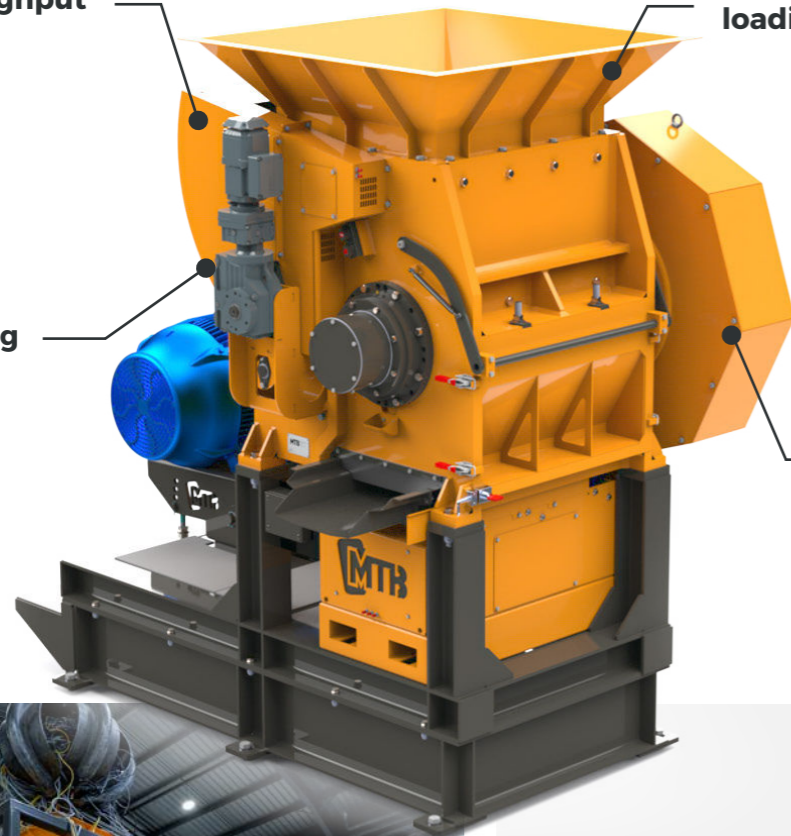

At the exit of the BVR

- Magnetic drum for larger ferrous inserts removal
- Buffer hopper including level sensors to ensure best material regulation and constant control on product flow
- On the conveyor, pull-wire emergency stop switches and rear cover to ensure operators' safety and machine cleanliness



TECHNICAL DATA	BVR 845
Power	75 HP - 45 kW
Rotor length	31,5" / 800 mm
Cutting speed	190 RPM
Blades	16

GRANULATION AREA

Equipped with our new BAT 445



New BAT 445

- Two identical units in series with enhanced rotor design for better throughput and reduced wear and tear
- Optimized cutting effect for better material liberation and speed-up sizing
- Automatic belt tension for energy savings and easier maintenance
- Super-fast screen replacement system



TECHNICAL DATA	BAT 445
Power	50 HP - 37 kW
Rotor length	15,8" / 400 mm
Cutting speed	480 RPM
Blades	14



BAT 445 blades

SORTING AREA

By combining density separation and size classification, MTB goes further in the search for obtaining the highest purity for end products. This process has been successfully used on our large-scale recycling lines for decades and makes a huge difference when it comes to market final chops.

New air table T 600

- Improved sealing
- Space-saving ventilation integrated into the lower part of the table
- Simplified setting device to quickly adjust on waste streams
- Maximize visibility on sorting deck for better control



Sieving table TAM 700

- Quick screen replacement design
- Optimal screen tensioning system to maintain sorting quality and extend parts lifetime
- Automatic screen-self-cleaning balls package to improve sorting efficiency

TECHNICAL DATA	T 600	TAM 700
Power	3 HP - 2,2 kW	2 x 350 W
Sieving dimensions	-	1320 x 640 mm
Air flow	5400 m3 / h	-

PLUG'N' RUN SOLUTION



The new compact line, MaX by MTB, a unique concept with a wide range of relevant features.

- Pre-assembled onto a 40' container floor, our new MaX solution offers reduced footprint requirements for easy install
- Power connection and a flat concrete slab is all that is required to set up and use this compact chopping line
- Fully integrated solution featuring pre-wiring and pre-ducting to allow fast commissioning
- Mobile, the MaX provides the higher comfort and flexibility of use

MAINTENANCE BENEFITS

- Tapping blade adjustment system duplicated from our larger flagship machineries
- Same blade model on shredder and granulators for easiest spare parts management
- Easy access and opening on all equipment
- Simplified maintenance operations mean reduced downtime and lowest operating costs
- Optimized transmission for easier maintenance and longer consumable life

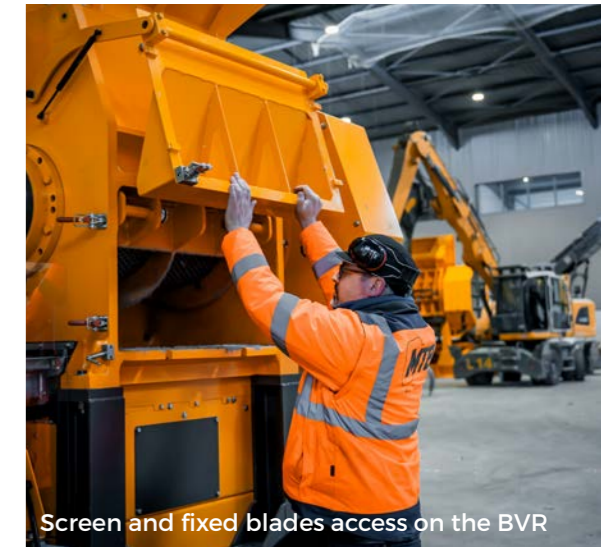

Screen and fixed blades access on the BVR

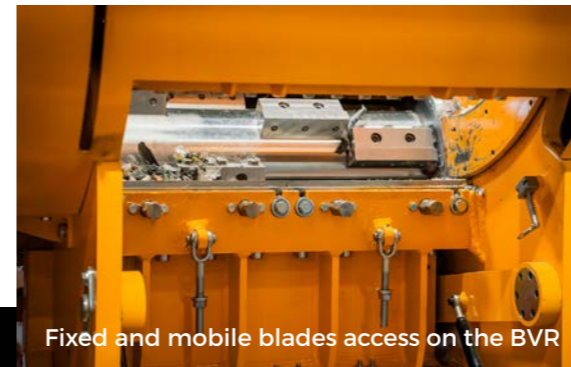

Fixed and mobile blades access on the BVR



Screen and fixed blades access on the BVR

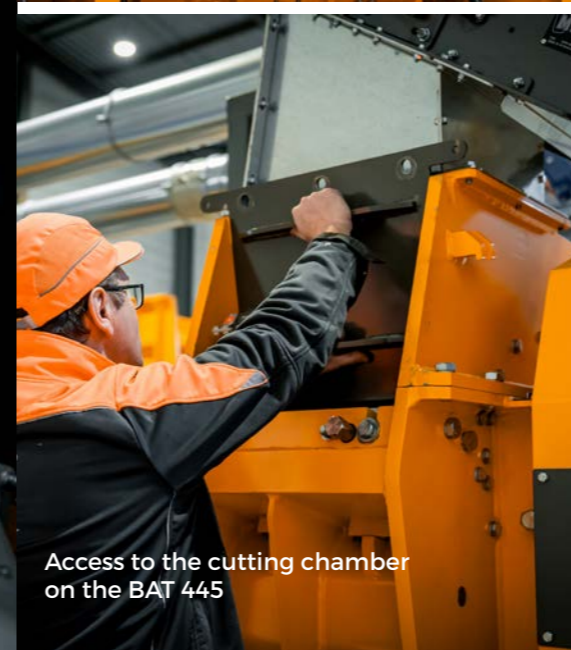

Access to the cutting chamber on the BAT 445



Easy screen tensioning on the sieving table TAM 700



TECHNICAL DATA

TECHNICAL DATA	MaX
Power	200 HP - 150 kW
Length	39'12" / 12,19 m
Width	8' / 2,44 m
Height	9'10" / 3,3 m
Weight	19 T

THE MAX'S BENEFITS AT A GLANCE

- Gradual size reduction in **3 steps** to increase **productivity**
- **One single blade model** for the entire process : the historical one at MTB
- Same robust design replicated from our larger shredders : **extended machines life**
- **Dedusting step** : hoses can be connected to existing systems (sourced by the customer) or with a filter unit supplied in option
- More flexible loading thanks to the **ram-equipped shredder**, eliminating the need of a grapple



MYMTB

An all-in-one tool for more productivity

MyMTB is an intelligent platform on which all your MTB equipment is connected. All machines from your entire system are constantly monitored and analyzed thanks to a powerful sensor system.

The MyMTB application processes all the data received in real time, and allows you to improve your use of MTB machines in order to obtain a better efficiency.

Through performance indicators, you will be able to analyze your production trends to optimize your installation but also anticipate maintenance needs.

All data is protected and stored in a secure area. You will be able to access it by authenticating yourself on the application, no matter where you are.

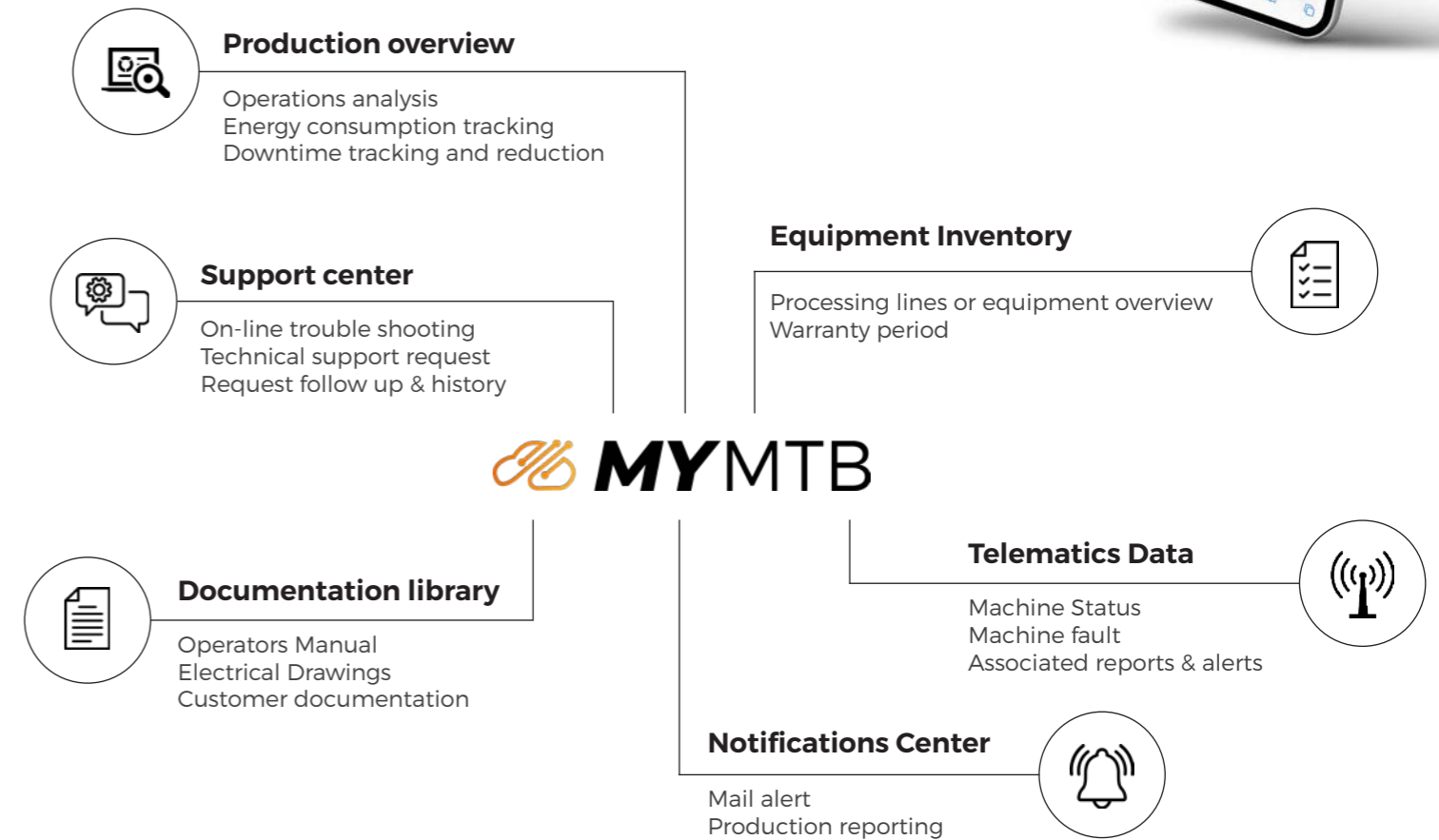
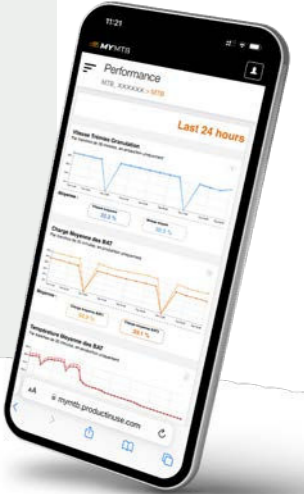

CUSTOMER SUPPORT

TRAINING AND COACHING

Our experts will train you before commissioning the machines, to give you the keys to success.

CUSTOMER SERVICE

We're here to advise, troubleshoot and supply spare parts at short notice.



INSTALLATION - MTB SERVICE

Technicians specialized in the installation and repair of our equipment, able to operate rapidly anywhere in the world.

CHARACTERIZATION AND ECO-DESIGN SUPPORT

Our eco-innovation team, the group's R&D unit, supports manufacturers in their circular economy initiatives.

We offer 4 levels of support :

- 1.AWARENESS
- 2.INVESTIGATION
- 3.IMPLEMENTATION
- 4.DEVELOPMENT



Visit our website

www.mtb.fr



Address : Parc d'activités des Balmes Dauphinoises, 38890, Saint-Chef, FRANCE

Mail : info@mtb.fr

Phone : +33 474 928 768